



ASIX

Low Power 3V to 5.5V 3D/5R 1000Kbps RS232 Transceivers

ZT3241F/ZT3243F

ZT3241F/ZT3243F
Low Power 3V to 5.5V 3D/5R 1000Kbps RS232 Transceivers
Datasheet

Revision 2.30
August 30th, 2019





ASIX

**ZT3241F/ZT3243F
Low Power 3V to 5.5V 3D/5R 1000Kbps RS232 Transceivers**

IMPORTANT NOTICE

Copyright © 2013-2019 ASIX Electronics Corporation. All rights reserved.

DISCLAIMER

No part of this document may be reproduced or transmitted in any form or by any means, electronic or mechanical, including photocopying and recording, for any purpose, without the express written permission of ASIX. ASIX may make changes to the product specifications and descriptions in this document at any time, without notice.

ASIX provides this document “as is” without warranty of any kind, either expressed or implied, including without limitation warranties of merchantability, fitness for a particular purpose, and non-infringement.

Designers must not rely on the absence or characteristics of any features or registers marked “reserved”, “undefined” or “NC”. ASIX reserves these for future definition and shall have no responsibility whatsoever for conflicts or incompatibilities arising from future changes to them. Always contact ASIX to get the latest document before starting a design of ASIX products.

TRADEMARKS

ASIX, the ASIX logo are registered trademarks of ASIX Electronics Corporation. All other trademarks are the property of their respective owners.



Features

- Meets or Exceeds the EIA/TIA-232F and CCITT V.28/V.24 Specifications for VCC at +3.3V ±10% and +5V ±10% Operations
- Interoperable with EIA/TIA-232 and adheres to EIA/TIA-562 down to a +2.7V power source
- Low quiescent current - 0.5mA typ., 1mA max.
- Low shutdown current (where applicable) - 1 μA typical, 10 μA max.
- Guaranteed data rate 1000Kbps
- Proprietary Switch-Capacitor Regulated Voltage Converters (patent pending)
- Proprietary AUTOGREEN Power Saving (patent pending)
- Latch-up Free
- ESD Protection for RS-232 I/O's
 - ±15KV Human Body Model (HBM)
 - ±15KV IEC61000-4-2 Air Gap Discharge
 - ±8KV IEC61000-4-2 Contact Discharge
- Pin and Function Compatible Replacements for MAX3245E, ICL3245, ISL4245E, and SP3243U
- Standard Data Rate at 250Kbps Available on ZT3243E Series

Applications

- Battery-Powered And Hand-Held Applications
- Notebooks, Subnotebooks, and Palmtops
- Industrial and Embedded PCs
- Data Cables for Cell Phones and PDAs
- Terminal Adapters and POS terminals
- Peripherals interface
- Routers and HUBs

General Description

The ZT3243F Series devices are 3V powered EIA/TIA-232 and V.28/V.24 communication interfaces with low power requirements. They consist of three line drivers, five line receivers and the proprietary switch-capacitor regulated voltage converters. These devices operate from a single 3V to 5.5V power supply at the guaranteed data rate of 1000K bits/sec with enhanced electrostatic discharge (ESD) protection in all RS232 I/O pins exceeding ±15KV IEC61000-4-2 Air Gap Discharge and ±8KV IEC61000-4-2 Contact Discharge.

The ZT3243F Series feature the AUTOGREEN (patent pending) proprietary function which automatically powers down the on-chip regulated voltage converters and driver circuits when an RS-232 cable is disconnected from the host interface or when a connected peripheral device is turned off.

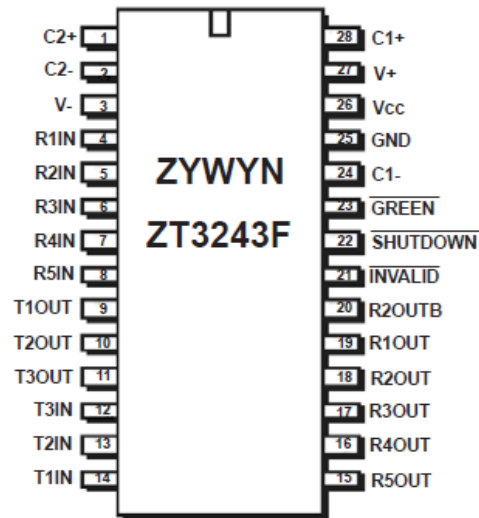

28-pin SSOP/TSSOP/WSOIC

Product Selection Guide and Cross Reference

Part Number	Power Supply	RS232 Drivers	RS232 Receivers	Data Rate (Kbps)	15KV ESD IEC61000 4-2	Receiver Enable	SHUTDOWN Enable	AUTOGREEN Function	Package Types	Pin-to-Pin Cross Reference
ZT3241F	+3V to +5.5V	3	5	1000	RS232 I/O	YES	YES	NO	28-SSOP, 28-TSSOP, 28-WSOIC	n/a
ZT3243F	+3V to +5.5V	3	5	1000	RS232 I/O	NO	YES	YES	28-SSOP, 28-TSSOP, 28-WSOIC, 32-VQFN	MAX3245E, ICL3245, ISL4245E, SP3243U



Absolute Maximum Ratings

These are stress ratings only and functional operation of the device at these ratings or any other above those indicated in the operation sections of the specifications is not implied. Exposure to absolute maximum rating conditions for extended periods of time may affect reliability.

Power Supply, (Vcc)	- 0.3V to +6.0V
V+	- 0.3V to +7.0V
V-	+0.3V to - 7.0V
V+ + V- 	+13.0V
Icc (DC Vcc or GND current)	±100mA

Input Voltages

TxIN, GREEN, SHUTDOWN, EN	- 0.3V to +6.0V
RxIN	±25V

Output Voltages

TxOUT	±15V
RxOUT, INVALID.....	- 0.3V to (Vcc +0.3V)

Short-Circuit Duration

TxOUT	Continuous
-------------	------------

Operating Temperature	- 40°C to +85°C
Storage Temperature	- 65°C to +150°C

Power Dissipation Per Package

28-pin SSOP (derate 9.52mW/°C above +70°C) ...	762mW
28-pin TSSOP (derate 13.20mW/°C above +70°C)	1W
28-pin WSOIC (derate 12.50mW/°C above +70°C)	1W
32-pin VQFN (derate 29.4mW/°C above +70°C) ..	2352mW

Storage Considerations

Storage in a low humidity environment is preferred. Large high density plastic packages are moisture sensitive and should be stored in Dry Vapor Barrier Bags. Prior to usage, the parts should remain bagged and stored below 40°C and 60%RH. If the parts are removed from the bag, they should be used within 168 hours or stored in an environment at or below 20%RH. If the above conditions cannot be followed, the parts should be baked for 12 hours at 125°C in order to remove moisture prior to soldering. ASIX ships product in Dry Vapor Barrier Bags with a humidity indicator card and desiccant pack. The humidity indicator should be below 30%RH. The MSL of this product is 3.

The information furnished by ASIX has been carefully reviewed for accuracy and reliability. Its application or use, however, is solely the responsibility of the user. No responsibility of the use of this information become part of the terms and conditions of any subsequent sales agreement with ASIX. Specifications are subject to change without the responsibility for any infringement of patents or other rights of third parties which may result from its use. No license or proprietary rights are granted by implication or otherwise under any patent or patent rights of ASIX Electronics Corporation.



1 Electrical Characteristics

Unless otherwise stated, $V_{CC} = +3.0V$ to $+5.0V$, $T_A = T_{min}$ to T_{max} , $C1$ to $C4 = 0.1 \mu F$, typical values apply at $V_{CC} = +3.3V$ or $+5.0V$ and $T_A = 25^\circ C$.

Parameter	Condition	Min	Typ	Max	Units
TTL Logic Input TTL Logic Output	$T1IN, T2IN, T3IN, \overline{GREEN}, \overline{SHUTDOWN}, \overline{EN}$ $R1OUT, R2OUT, R3OUT, R4OUT, R5OUT, R1OUTB,$ $R2OUTB, \overline{INVALID}$				
RS-232 Input RS-232 Output Charge Pump Pin Power Pin	$R1IN, R2IN, R3IN, R4IN, R5IN$ $T1OUT, T2OUT, T3OUT$ $C1P, C1N, C2P, C2N$ $V_{CC}, V_{GND}, V_{DD}, V_{SS}$				
Charge Pump Caps	$C1P, C1N, C2P, C2N$	0.1	0.1	1	μF
Temp $0^\circ C$ to $+70^\circ C$	Commercial Grade	0	+25	+70	$^\circ C$
Temp $-40^\circ C$ to $+85^\circ C$	Industrial Grade	-40	+25	+85	$^\circ C$
V_{CC} Voltage Range	$V_{CC} = +5.0V$ Supply $V_{CC} = +3.3V$ Supply	4.5 3	5 3.3	5.5 3.6	V
Supply Current	TTL Inputs = V_{CC}/GND , RS-232 Input = float, $V_{CC} = 3.3V$		0.5	1	mA
Supply Current, AUTOGREEN Disabled	$\overline{GREEN} = V_{CC}; \overline{SHUTDOWN} = V_{CC}; \overline{EN} = GND$ TTL Inputs = V_{CC}/GND , RS-232 Input = float, $V_{CC} = 3.3V$		0.5	1	mA
Supply Current, AUTOGREEN Enabled	$\overline{GREEN} = GND; \overline{SHUTDOWN} = V_{CC}; \overline{EN} = GND$ TTL Inputs = V_{CC}/GND , RS-232 Input = float, $V_{CC} = 3.3V$		1	10	μA
Supply Current, SHUTDOWN Enabled	$\overline{GREEN} = V_{CC}/GND; \overline{SHUTDOWN} = GND; \overline{EN} = V_{CC}$ TTL Inputs = V_{CC}/GND , RS-232 Inputs = float, $V_{CC} = 3.3V$		1	10	μA
TTL LOGIC Input Input Threshold Low Input Threshold High Input Threshold High Input Hysteresis Input Leakage Current	$V_{CC} = +5.0V$ Supply $V_{CC} = +3.3V$ Supply $V_{IN} = V_{CC}$ and GND, $T1N, \overline{EN}, \overline{GREEN}, \overline{SHUTDOWN}$	2.4 2	0.5 ± 0.01	0.8 ± 1	V V V V μA
TTL LOGIC Output Output Voltage Low Output Voltage High Output Leakage Current	$I_{OUT} = 1.6mA$ $I_{OUT} = -1.0mA$ Receiver Outputs Disabled, $V_{OUT} = V_{CC}$ or GND, $\overline{SHUTDOWN} = GND, \overline{EN} = V_{CC}$	$V_{CC} - 0.6$	$V_{CC} - 0.1$ ± 0.05	0.4 ± 10	V V μA
Receiver Input Input Voltage Range Input Threshold Low Input Threshold High Input Hysteresis Input Resistance	$T_A = T_{min} - T_{max}$ $T_A = 25^\circ C, V_{CC} = 5.0V$ $T_A = 25^\circ C, V_{CC} = 3.3V$ $T_A = 25^\circ C$ $T_A = 25^\circ C$ $V_{IN} = \pm 25V, T_A = 25^\circ C$	-25 0.8 0.6 3	1.5 1.2 0.5	25 2.4 7	V V V V K Ω
Transmitter Output Output Voltage Swing Output Resistance Output Short-Circuit Current Output Leakage Current	$R_L = 3K\Omega$, All Outputs are loaded $V_{CC} = V_{DD} = V_{SS} = GND, V_{OUT} = \pm 2V$ $V_{OUT} = GND$ Transmitter Disabled, $V_{OUT} = \pm 12V$	300	± 5 ± 5	± 60 ± 25	V Ω mA μA
Mouse Driving Ability Transmitter Output Voltage	$T1IN=T2IN=GND; T3IN=V_{CC}; T3OUT=3K\Omega;$ $T1OUT=T2OUT=-2.5mA$		± 5		V

Parameter	Condition	Min	Typ	Max	Units
Timing Characteristics					
Maximum Data Rate	RL=3~7KΩ, CL=250pF; 1 DR/RC Switching, TA = 25°C	1000			Kbps
Transition-Region Slew Rate	RL = 3~7KΩ, CL = 150pF ~ 250pF, One Transmitter Switching, TA = 25°C, Measured from 3V to -3V or -3V to 3V		60		V/μs
Transmitter Propagation tPLH	RL=3KΩ, CL=150pF; All loaded		2		μs
Transmitter Propagation tPHL	RL=3KΩ, CL=150pF; All loaded		2		μs
Transmitter Skew	tPHL - tPLH		100		ns
Transmitter Output Enable Time			400		ns
Transmitter Output Disable Time			250		ns
Receiver Propagation tPLH	CL = 150pF		0.15		μs
Receiver Propagation tPHL	CL = 150pF		0.15		μs
Receiver Skew	tPHL - tPLH		50		ns
Receiver Output Enable Time			200		ns
Receiver Output Disable Time			200		ns
AUTOGREEN Timing					
Receiver Input to $\overline{\text{INVALID}}$ Output High				1	μs
Receiver Input to $\overline{\text{INVALID}}$ Output Low				30	μs
Power Save Mode to Transmitter Enabled			100		μs
ESD Tolerance					
ESD HBM			±15		KV
IEC 1000-4-2 Contact Discharge			±8		KV
IEC 1000-4-2 Air Gap Discharge			±15		KV

2 Pin Description

Pin Numbers			Pin Name	Pin Description
ZT3241F	ZT3243F			
28 Pins SSOP/ TSSOP/ WSOIC	28 Pins SSOP/ TSSOP/ WSOIC	32 Pins VQFN		
1	1	29	C2+	Positive terminal of the inverted voltage switch capacitor
2	2	30	C2-	Negative terminal of the inverted voltage switch capacitor
3	3	31	V-	Regulated -5.7V output generated by the voltage converter
4	4	1	R1IN	First RS232 receiver input
5	5	2	R2IN	Second RS232 receiver input
6	6	3	R3IN	Third RS232 receiver input
7	7	4	R4IN	Fourth RS232 receiver input
8	8	5	R5IN	Fifth RS232 receiver input
9	9	6	T1OUT	First RS232 transmitter output
10	10	7	T2OUT	Second RS232 transmitter output
11	11	8	T3OUT	Third RS232 transmitter output
-	-	9, 16, 25, 32	NC	No connect
12	12	10	T3IN	Third TTL/CMOS transmitter input
13	13	11	T2IN	Second TTL/CMOS transmitter input
14	14	12	T1IN	First TTL/CMOS transmitter input
15	15	13	R5OUT	Fifth RS232 receiver output
16	16	14	R4OUT	Fourth RS232 receiver output
17	17	15	R3OUT	Third RS232 receiver output
18	18	17	R2OUT	Second RS232 receiver output
19	19	18	R1OUT	First RS232 receiver output
20	20	19	R2OUTB	Second RS232 receiver non-inverting output. Always active.
-	21	20	INVALID	Output of a valid signal detection. INVALID is enabled high if a valid RS232 level is present on any receiver input line
21	-		.R1OUTB	First RS232 receiver non-inverting output. Always active
22	22	21	SHUTDOWN	Shutdown control. A logic LOW to disable drivers and voltage converter
23	-	-	EN	Receiver Enable. Logic LOW for normal operation. Logic HIGH to force the receiver outputs into high impedance state
-	23	22	GREEN	A logic HIGH to override AUTOGREEN circuitry keeping transmitters on. (SHUTDOWN must be HIGH)
24	24	23	C1-	Negative terminal of the bootstrapped voltage switch capacitor
25	25	24	GND	Ground pin of the device
26	26	26	V _{CC}	+3V to +5.5V Supply Voltage
27	27	27	V+	Regulated +5.4V output generated by the voltage converter
28	28	28	C1+	Positive terminal of the bootstrapped voltage switch capacitor

3 Circuit Description

Proprietary Switch-Capacitor Regulated Voltage Converter

Different from other suppliers, ASIX uses a patent pending switch-capacitor voltage-controlled source and sink current generators design to provide powerful bipolar voltages to maintain compliant EIA/RS232 levels regardless of power supply fluctuations. The design consists of an internal regulated oscillator, a two phase clock cycling, regulated complementary MOS switches, fast switching diode and switch capacitors.

The switch capacitor bi-directional current generators operate with ASIX' s proprietary smartly regulated complementary MOS switches and fast switching diode from its proprietary high voltage process technology. The efficiency of these bidirectional current generators is well over 70%. The switching frequency is generated by an internal oscillator and regulated by the current loads. The switch capacitor pump design delivers higher negative bucked voltage than the positive boosted voltage to achieve a balanced voltage controlled source and sink current generators resulting a balanced bipolar voltage supplies to the chip.

With its unique proprietary design technique, ASIX' s interface product series provide a better power efficient, stable and compliant EIA/RS232 levels with superior low power consumption.

Controlled Power-Down

The ZT3243F series products have a low-power shutdown mode controlled by the SHUTDOWN pin. During shutdown the driver output and the switch-capacitor regulated voltage converter are disabled with the supply current falls to less than 1 μ A.

The ZT3243F uses ASIX' s patent pending AUTOGREEN circuitry to set/reset latches, which enable the circuit shutdown function when a RS232 cable is disconnected or when the peripheral is turned off and reduce the power supply drain to a 1 μ A supply current. Otherwise, when a RS232 cable is connected or when the peripheral is turned on, the devices will automatically become active again.

ESD Immunity

Electro-Static Discharge (ESD) is an important factor when implementing a serial port into a system. In some applications, it is crucial that the ESD protection for the system must meet a certain tolerance level. Since RS232 transceiver devices are exposed to the outside world, there are many environmental factors that can affect the serial port and even subject it to transients that could potentially damage the transceiver itself.

The RS232 transceiver is usually routed from the serial port connector to the transceiver IC through the metal trace on the printed circuit board. This trace will have some small amount of resistance that will add some protection in terms of limiting transient current to the IC. However for added voltage protection, transient voltage suppressors (TVS) or transzorb, which are back-to-back diode arrays clamp, are usually necessary to protect the serial port circuitry.

To further reduce cost within their system, more engineers are requiring higher ESD tolerances from the transceiver ICs themselves without having to add costly TVS circuitry. ASIX's RS232 transceivers include built-in transient voltage suppression where external ESD circuitry is not necessary to meet the MIL-STD-883, Method 3015, Human Body Model and the EN61000-4-2 Air/Contact Discharge tests.

The Human Body Model has been the generally accepted ESD testing method for semiconductors. This test is intended to simulate the human body's potential to store electrostatic energy and discharge it to an integrated circuit upon close proximity or contact. This method will test the IC's capability to withstand an ESD transient during normal handling such as in manufacturing areas where the ICs tend to be handled frequently.

EN61000-4-2 is used for testing ESD on equipment and systems. For system manufacturers, they must guarantee a certain amount of ESD protection since the system itself is exposed to the outside environment and human presence. EN61000-4-2 specifies that the system is required to withstand an amount of static electricity when ESD is applied to exposed metal points and surfaces of the equipment that are accessible to personnel during normal usage. The transceiver IC receives most of the ESD current when the ESD source is applied to the connector pins.

There are two methods within EN61000-4-2, the Air Discharge method and the Contact Discharge method. With the Air Discharge Method, an ESD voltage is applied to the equipment under test through air, which simulates an electrically charged person ready to connect a cable onto the rear of the system and the high energy potential on the person discharges through an arcing path to the rear panel of the system before he or she even touches the system. The Contact Discharge Method applies the ESD current directly to the EUT. This method was devised to reduce the unpredictability of the ESD arc. The discharge current rise time is constant since the energy is directly transferred without the air-gap arc inconsistencies.

ASIX's RS232 transceivers meets and exceeds the minimum criteria for EN61000-4-2 with $\pm 15\text{KV}$ for Air Gap Discharge and $\pm 8\text{KV}$ for Contact Discharge.

Product	GREEN	Valid RC I/P	SHUTDOWN	EN	TxOUT	RxOUT	RxOUTB	INVALID
ZT3241F	n/a	n/a	0	0	Z	active	active	n/a
			0	1	Z	Z	active	
			1	0	active	active	active	
			1	1	active	Z	active	
ZT3243F	0	no	1	n/a	Z	active	active	0
	0	present	1		active	active	active	1
	1	x	1		active	active	active	x
	x	x	0		Z	Z	active	x

Table 1: ZT3241F/ZT3243F Output Control Truth Table

4 Pin Configuration

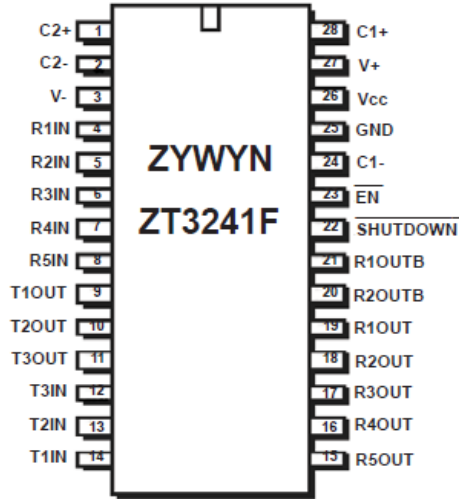

28-Pin SSOP/TSSOP/WSOIC

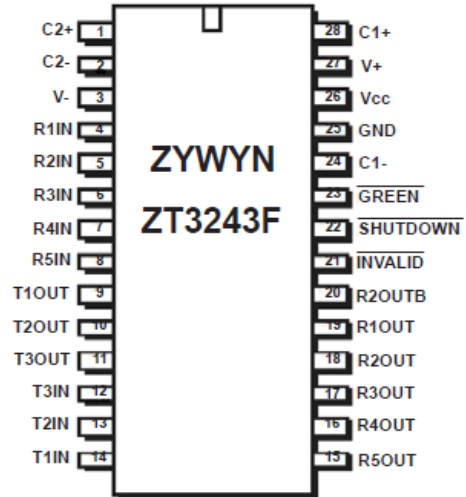

28-Pin SSOP/TSSOP/WSOIC

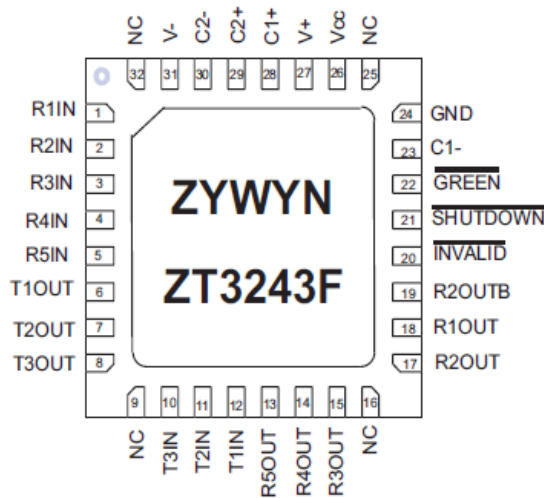

32-Pin VQFN

5 Typical Application Circuits

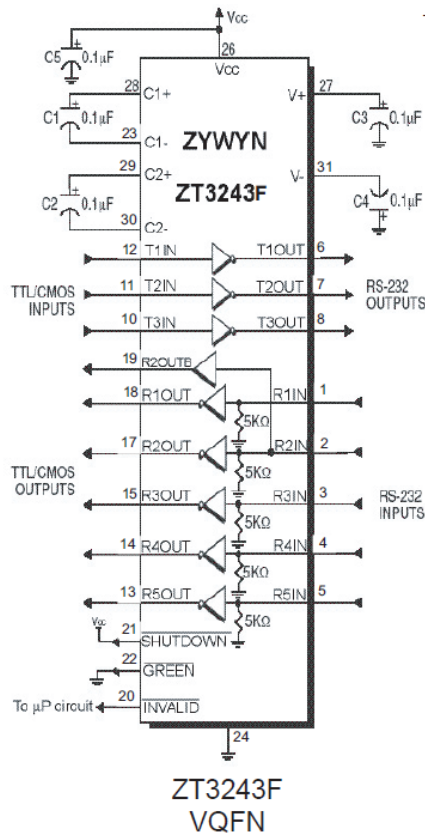
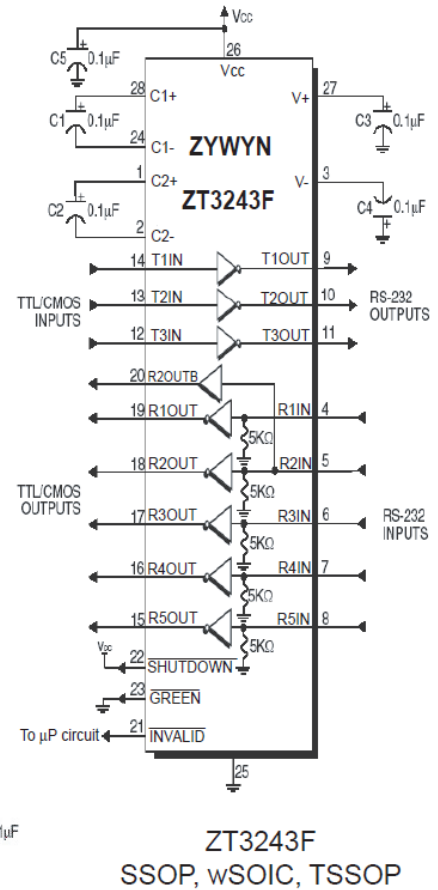
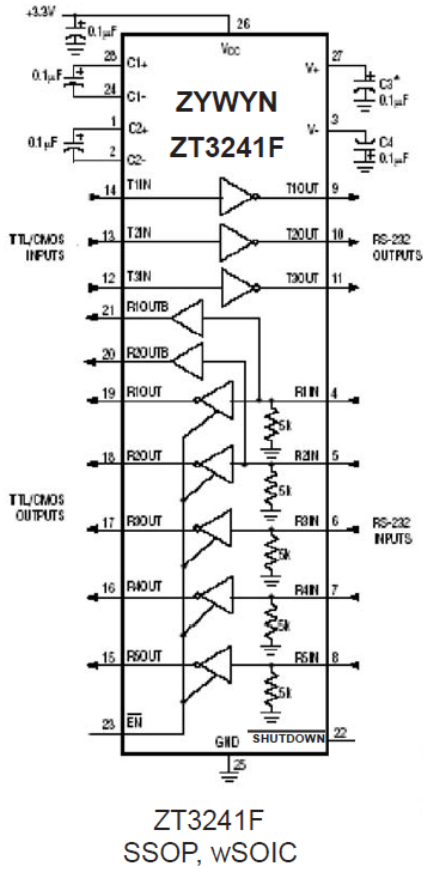

6 Package Information

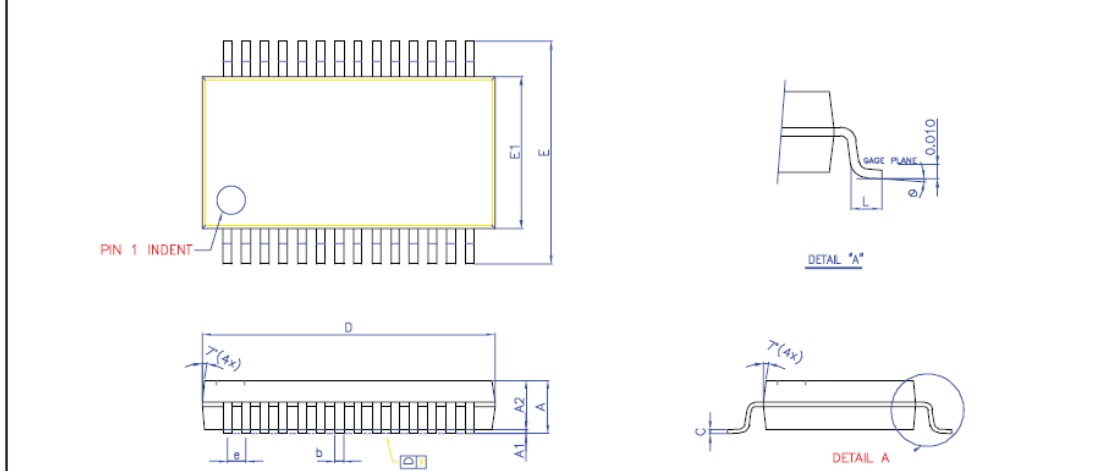

28-pin SSOP

NOTE :

- CONTROLLING DIMENSION : mm
- LEAD FRAME MATERIAL : COPPER 194
- DIMENSION "D" DOES NOT INCLUDE MOLD FLASH, THE BAR BURRS AND GATE BURRS. MOLD FLASH, THE BAR BURRS AND GATE BURRS SHALL NOT EXCEED 0.006[0.15mm] PER END DIMENSION "E1" DOES NOT INCLUDE INTERLEAD FLASH, INTERLEAD FLASH SHALL NOT EXCEED 0.010[0.25mm] PER SIDE.
- DIMENSION "b" DOES NOT INCLUDE DAMBAR PROTRUSION, ALLOWABLE DAMBAR PROTRUSION SHALL BE 0.003[0.08mm] TOTAL IN EXCESS OF THE "b" DIMENSION AT MAXIMUM MATERIAL CONDITION, DAMBAR CANNOT BE LOCATED ON THE LOWER RADII OR THE FOOT, MINIMUM SPACE BETWEEN PROTRUSION AND AN ADJACENT LEAD TO BE 0.0028[0.07mm]
- TOLERANCE : ±0.010[0.25mm] UNLESS OTHERWISE SPECIFIED.
- OTHERWISE DIMENSION FOLLOW ACCEPTABLE SPEC.
- REFERENCE DOCUMENT : JEDEC SPEC MO-150

SYMBOLS	DIMENSIONS IN MILLIMETERS			DIMENSIONS IN INCHES		
	MIN	NOM	MAX	MIN	NOM	MAX
A	—	—	2.00	—	—	0.079
A1	0.05	—	—	0.002	—	—
A2	—	1.75	—	—	0.069	—
b	0.22	0.30	0.38	0.0086	0.012	0.015
C	0.13	0.16	0.20	0.0051	0.006	0.0079
D	10.08	10.20	10.34	0.397	0.402	0.407
E	7.40	7.80	8.20	0.291	0.307	0.323
E1	5.00	5.30	5.60	0.197	0.209	0.220
e	—	0.65	—	—	0.0256	—
L	0.56	0.75	0.97	0.022	0.030	0.037
φ	—	4"	8"	—	4"	8"
y	—	—	0.076	—	—	0.003

CUSTOMER : ZYWYN CORPORATION

APPROVED BY : DATE : TITLE :

DRAW BY: *Ming Chen* 10/01/09 TITLE: 28L (200°) BODY .026" LEAD PITCH SMALL OUTLINE PACKAGE DRAWING

CHECK BY: *Yao Chen* 11/02/09

APPROVAL: *Yao Chen* 11/02/09 DWG. NO. PO-SSOP-011 REV. 0

APPROVAL: *Jack Tu* 11/02/09 UNIT : mm SCALE : 10/1 SHEET 1 OF 1

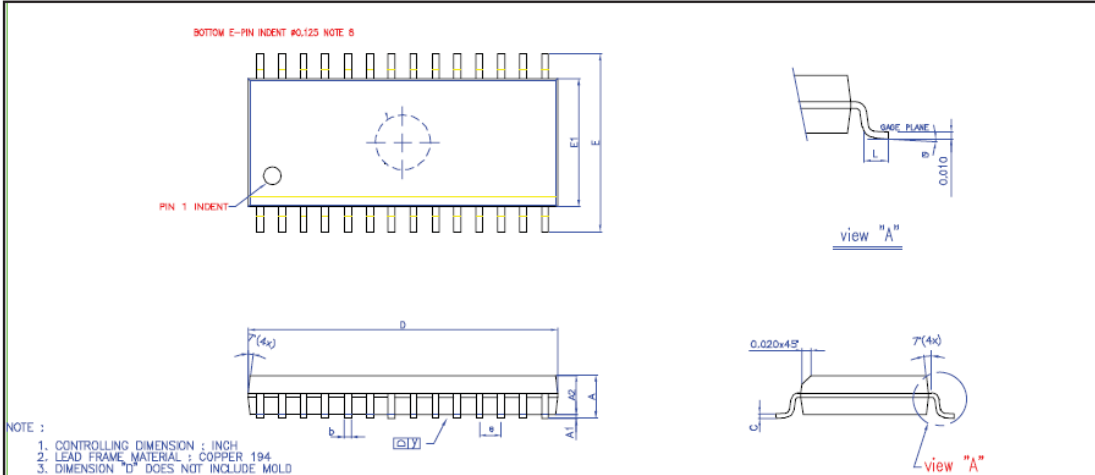

28-pin WSOIC

NOTE :

- CONTROLLING DIMENSION : INCH
- LEAD FRAME MATERIAL : COPPER 194
- DIMENSION "D" DOES NOT INCLUDE MOLD FLASH, THE BAR BURRS AND GATE BURRS. MOLD FLASH, THE BAR BURRS AND GATE BURRS SHALL NOT EXCEED 0.006[0.15mm] PER END DIMENSION "E1" DOES NOT INCLUDE INTERLEAD FLASH, INTERLEAD FLASH SHALL NOT EXCEED 0.010[0.25mm] PER SIDE.
- DIMENSION "b" DOES NOT INCLUDE DAMBAR PROTRUSION, ALLOWABLE DAMBAR PROTRUSION SHALL BE 0.003[0.08mm] TOTAL IN EXCESS OF THE "b" DIMENSION AT MAXIMUM MATERIAL CONDITION, DAMBAR CANNOT BE LOCATED ON THE LOWER RADII OR THE FOOT, MINIMUM SPACE BETWEEN PROTRUSION AND AN ADJACENT LEAD TO BE 0.0028[0.07mm]
- TOLERANCE : ±0.010[0.25mm] UNLESS OTHERWISE SPECIFIED.
- OTHERWISE DIMENSION FOLLOW ACCEPTABLE SPEC.
- REFERENCE DOCUMENT : JEDEC SPEC MS-013
- BOTTOM E-PIN INDENT IN MARKED AS BELOW :

BOTTOM E-PIN INDENT #0.125 NOTE B

view "A"

view "A"

SYMBOLS	DIMENSIONS IN MILLIMETERS			DIMENSIONS IN INCHES		
	MIN	NOM	MAX	MIN	NOM	MAX
A	2.36	2.49	2.64	0.093	0.098	0.104
A1	0.10	—	0.30	0.004	—	0.012
A2	—	2.34	—	—	0.092	—
b	0.33	0.41	0.51	0.013	0.016	0.020
C	0.23	0.26	0.30	0.009	0.010	0.012
D	17.70	17.91	18.11	0.697	0.705	0.713
E	10.01	10.31	10.64	0.394	0.406	0.419
E1	7.39	7.49	7.59	0.291	0.295	0.299
e	—	1.27	—	—	0.050	—
L	0.38	0.81	1.27	0.015	0.032	0.050
y	—	—	0.076	—	—	0.003
φ	0"	—	8"	0"	—	8"

CUSTOMER : ZYWYN CORPORATION

APPROVED BY : DATE : TITLE :

DRAW BY: *Ming Chen* 10/01/09 TITLE: 28L WIDE BODY SMALL OUTLINE PACKAGE DRAWING





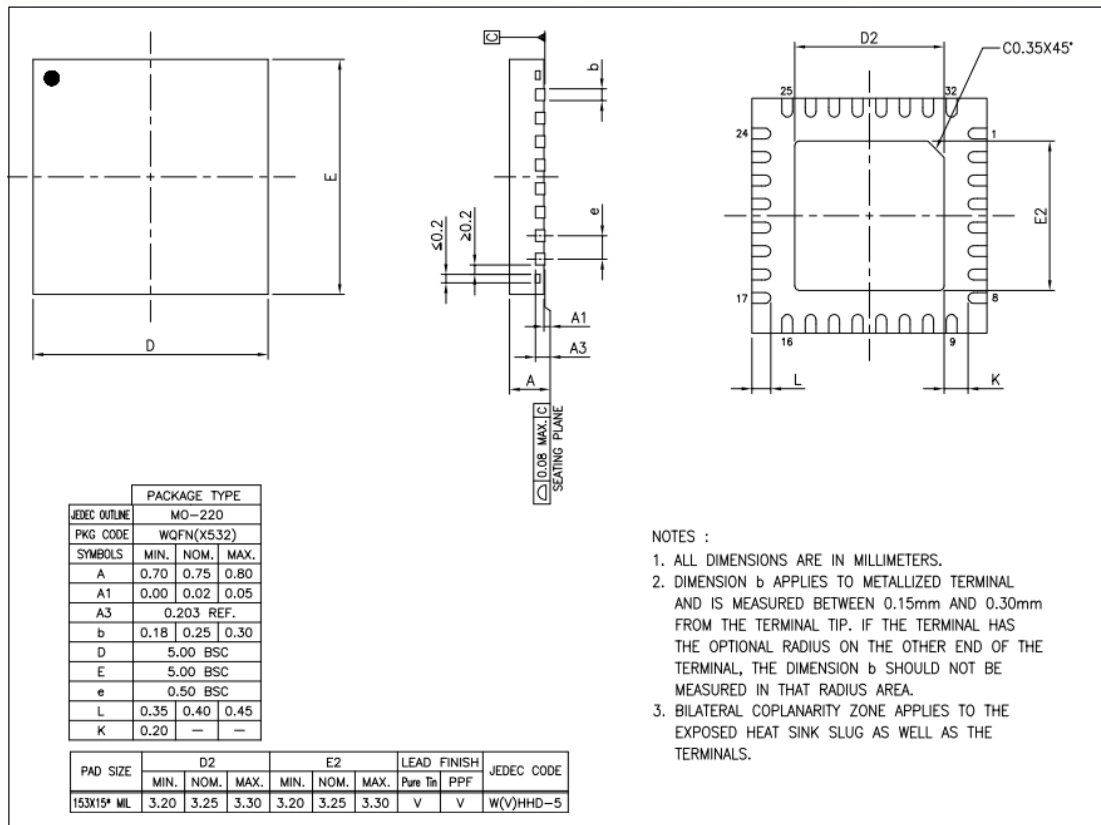
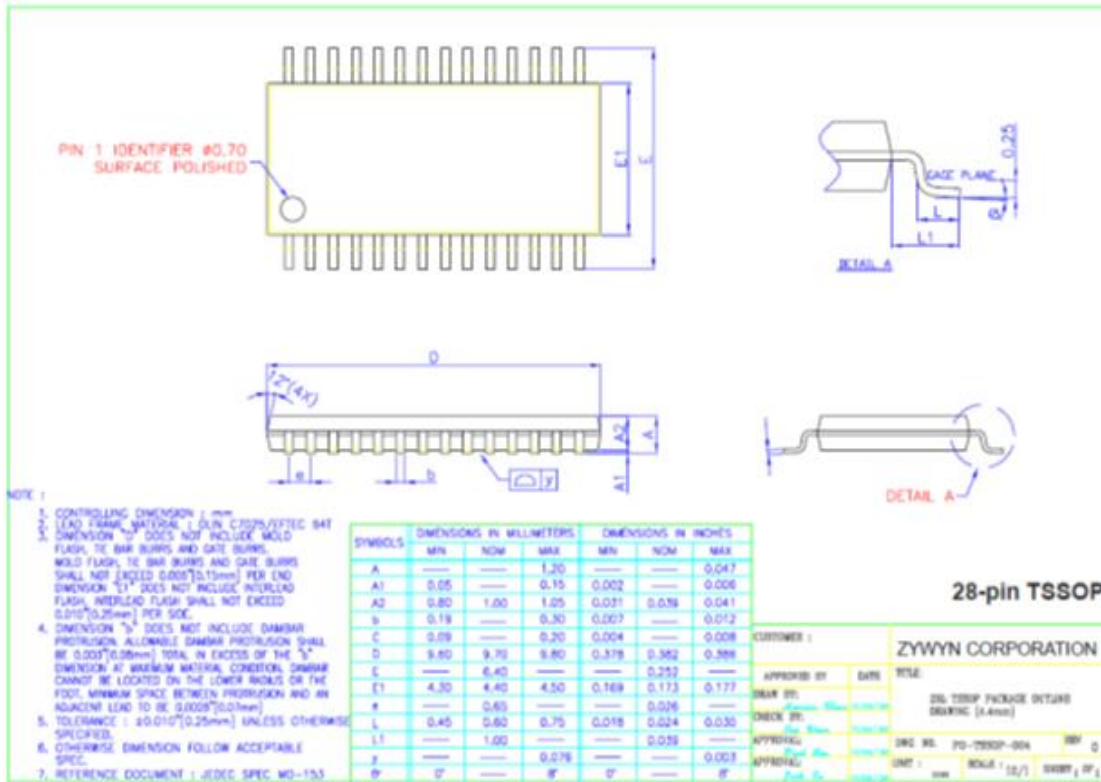

CHECK BY: *Yao Chen* 11/02/09

APPROVAL: *Yao Chen* 11/02/09 DWG. NO. PO-SOP-008 REV. 0

APPROVAL: *Jack Tu* 11/02/09 UNIT : INCH SCALE : 6/1 SHEET 1 OF 1



7 Ordering Information

Part Number	Temperature Range	Package Type	Green Package
ZT3241LFEA	-40°C to +85°C	28-pin SSOP	
ZT3241LFET	-40°C to +85°C	28-pin WSOIC	
ZT3241LFEY	-40°C to +85°C	28-pin TSSOP	
ZT3243LFEA	-40°C to +85°C	28-pin SSOP	
ZT3243LFET	-40°C to +85°C	28-pin WSOIC	
ZT3243LFEY	-40°C to +85°C	28-pin TSSOP	
ZT3243LFEQ	-40°C to +85°C	32-pin VQFN	

Please contact the factory for pricing, availability on Tape-and-Reel options.

8 Part Marking Information

TOPSIDE MARK INSTRUCTIONS:

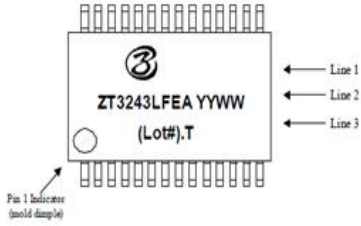

Line 1: Zywyn (logo)
 Line 2: Zywyn Part Number "ZT3243LFEA", Space " ", Date Code (Prod Year & Week)
 Line 3: Lot #, dot and Country ".T"
 Note: Pin # 1 "○" Indicator Required if no mold dimple

BOTTOMSIDE MARK INSTRUCTIONS:

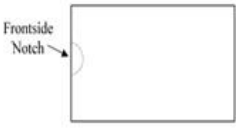

No backside marking

TOPSIDE MARK INSTRUCTIONS:



Line 1: Zywyn (logo)
 Line 2: Zywyn Part Number "ZT3243LF"
 Line 3: Zywyn Part Number cont. "EQ", Space " ", Date Code: (Year & Work Week)
 Line 4: Country of Origin "TW", Last 5-digit of Lot Number
 Note: Pin # 1 "○" Indicator Required if no Mold Dimple

BOTTOMSIDE MARK INSTRUCTIONS:

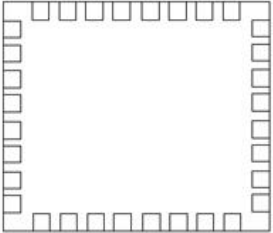

Revision History

Revision	Date	Comment
V1.4	2013/05/01	Initial release to customers
V2.00	2015/04/21	1. Changed to ASIX Electronics Corp. logo, strings and contact information. 2. Added ASIX copyright legal header information. 3. Modified the Revision History table format.
V2.10	2017/09/05	Updated the Marking Information in Section 8.
V2.20	2019/08/20	Corrected Package Information
V2.30	2019/08/30	Corrected Section 1. Information.



ASIX

ZT3241F/ZT3243F
Low Power 3V to 5.5V 3D/5R 1000Kbps RS232 Transceivers

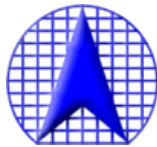

ASIX Electronics Corporation.

4F, No. 8, Hsin Ann Rd., HsinChu Science Park,
HsinChu, Taiwan, R.O.C.

TEL: 886-3-5799500

FAX: 886-3-5799558

Sales Email: sales@asix.com.tw

Support Email: support@asix.com.tw

Web: <http://www.asix.com.tw>